









Vanity Sink Base Cabinet Assembly Instruction

(Item:VSD3621)

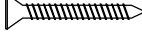
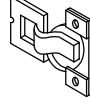
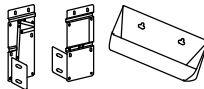
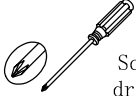
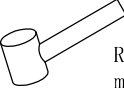
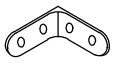
Hardware list	1 4pcs $\varnothing 4 \times 16\text{mm}$ Flat head screw	2 2pcs $\varnothing 4 \times 19\text{mm}$ Round head screw	3 20pcs $\varnothing 3.5 \times 14\text{mm}$ Color galvanized screw with flat head	4 10pcs $\varnothing 3.5 \times 16\text{mm}$ Color galvanized screw with flat head	5 7pcs $\varnothing 3.5 \times 35\text{mm}$ Black screw with flat head	6 2pcs 1-1/4" Hinge	7 1set M1-L/R CW11 Overhead door hinge
							
Assembly tools required	 Screw driver	 Rubber mallet	H Drawer front	11 4pcs 40mmx40mm Bracket rainbow 90°	10 12pcs $\varnothing 7$ Bumper	9 4set L-shape bracket	8 2set S30B457H10GA08 Drawer slide
							
Cabinet Part List	A Front frame	B Side panel(2)	C Bottom panel	D Back panel	E Toe kick panel	F Adjustable shelf	G Door

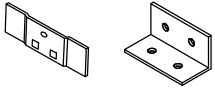
Step 1 : With front frame (A) of cabinet lay down on clean and soft surface then put glue into groove.

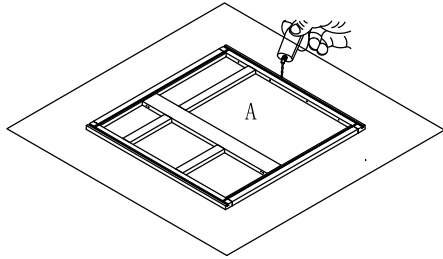

Step 2 : Install side panel. Insert both side panel (B) into groove of front frame (A) until side panel (B) and front frame (A) even.

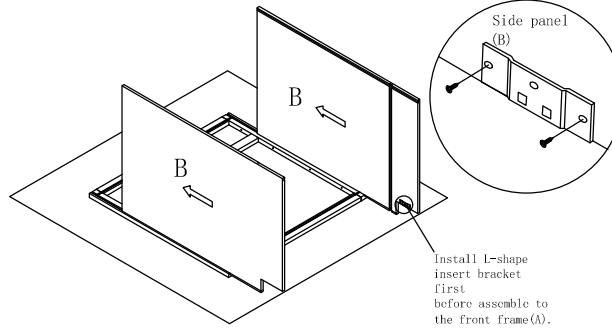

Step 3 : Install bottom panel. Insert the bottom panel (C) into groove of side panel (B) until it into the groove of front frame (A).

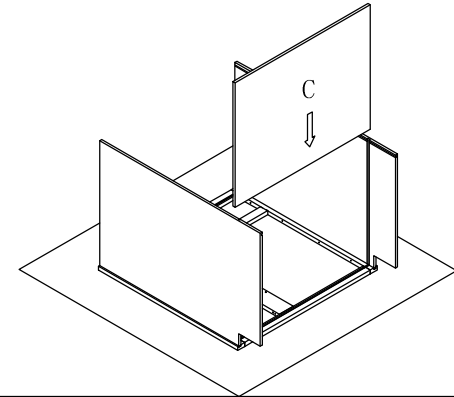

Step 4 : Install back panel. Insert back panel (D) into groove of left and right side panel (B).

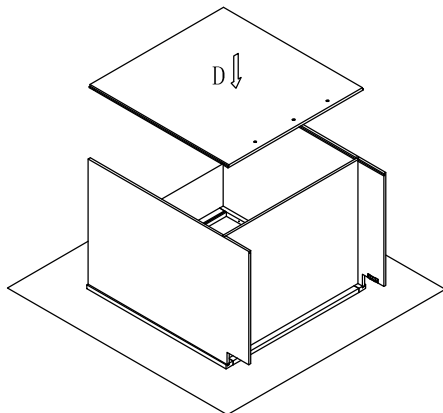

Step 5 : Install screw (5) $\varnothing 3.5 \times 35\text{mm}$ into back panel (D).

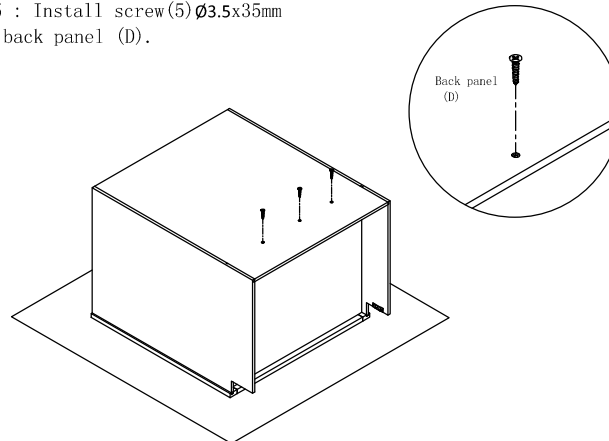

Step 6 : Install toe kick panel. Fit in the L-shape insert bracket from toe kick panel (E) into side panel (B) bracket and screw the bracket with (3) $\varnothing 3.5 \times 14\text{mm}$ screw.

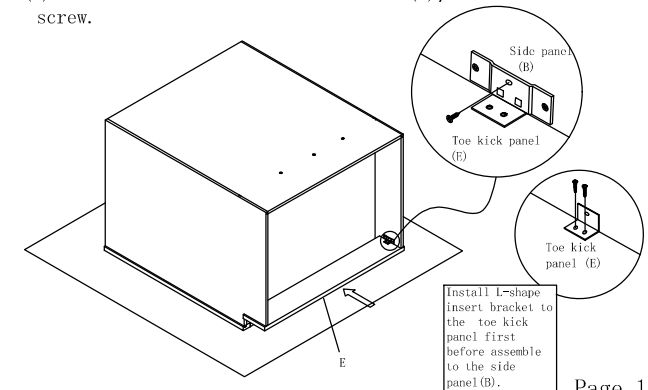

Vanity Sink Base Cabinet Assembly Instruction

(Item:VSD3621)

Step 7 : Install back panel. Fit in the L-shape insert bracket from back panel (D) into side panel (B) bracket and assembly the bracket with (3) $\varnothing 3.5 \times 14$ mm screw.

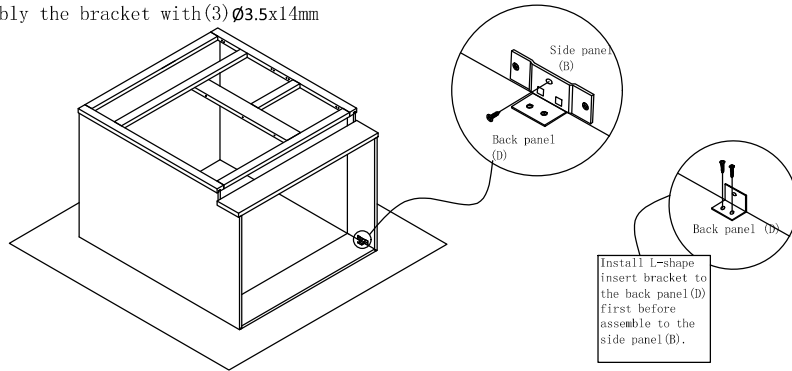

Step 8 : Install corner block. Install rainbow bracket to the side panel (B), front frame (A) and back panel (D) with the (4) $\varnothing 3.5 \times 16$ mm screw.

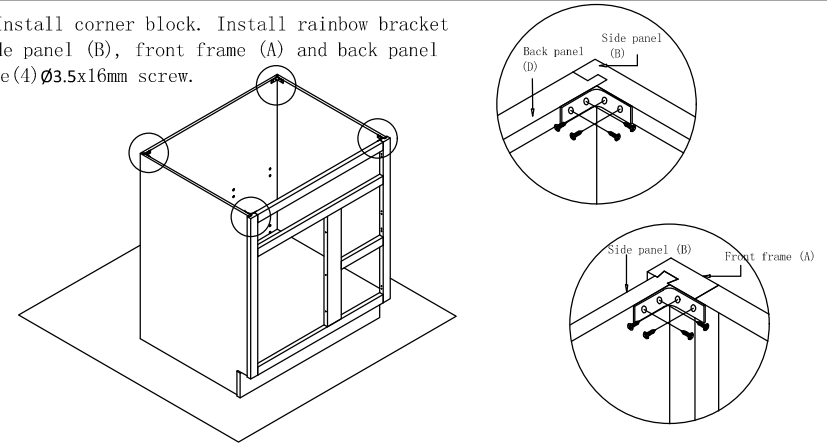

Step 9 : Install the drawer slide rear bracket. Screw the rear slide bracket to the back panel (D).

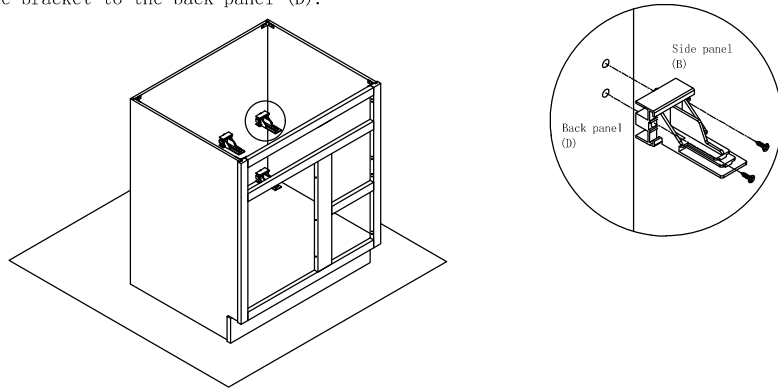

Step 10 : Insert drawer slide runner to the rear slide bracket and screw the drawer slide to the guide hole of front frame (A) and hole for drawer slide

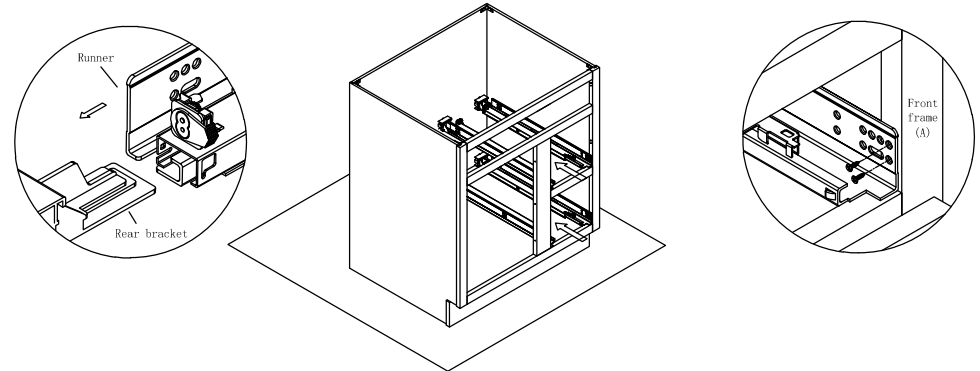

Step 11 : Put the drawer box on the drawer slide and push the drawer box to make the end of runner is lock to the hole of the drawer back panel. Complete the installation of the drawer box when you hear sound click which mean the locking device is locked on the drawer slide.

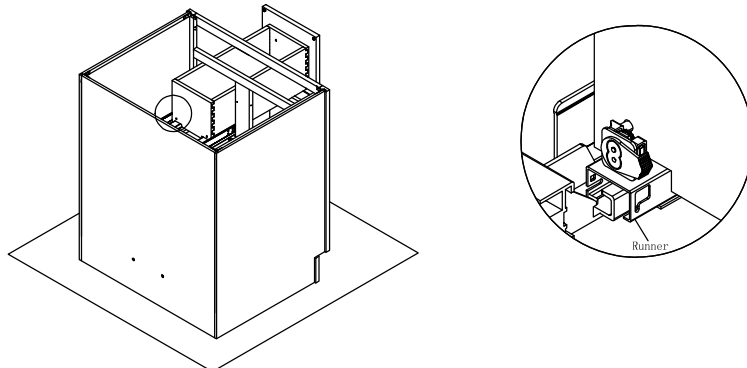

Step 12 : Install door panel (G). Screw the hinge to the front frame (A) and door (G).

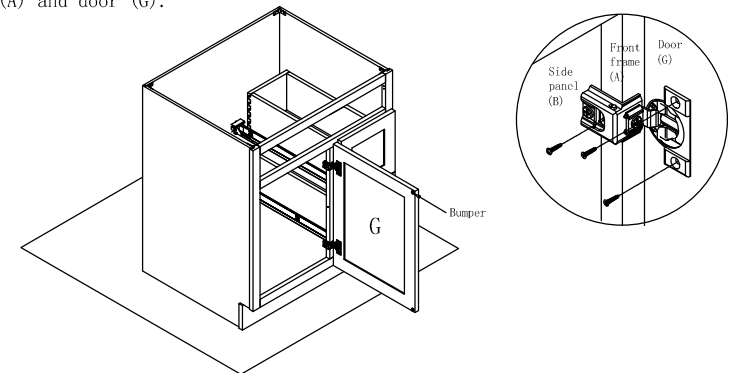

Vanity Sink Base Cabinet Assembly Instruction

(Item:VSD3621)

Step 13 : Screw wood connect on the front frame.

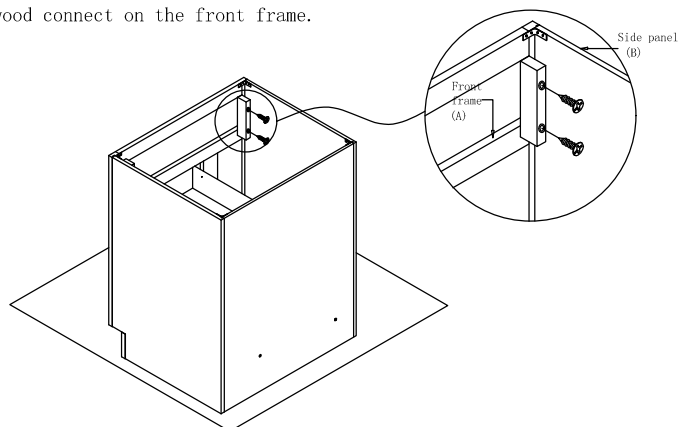

Step 14 : Install overhead door hinge . Screw the overhead door hinge to the connection wood .

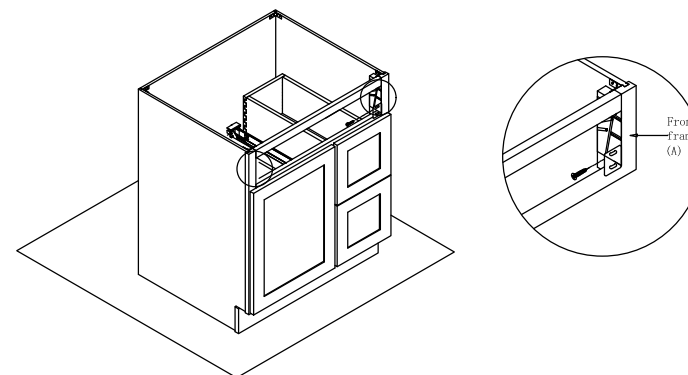

Step 15 : Install drawer front , then install the overhead door hinge box to the drawer front.

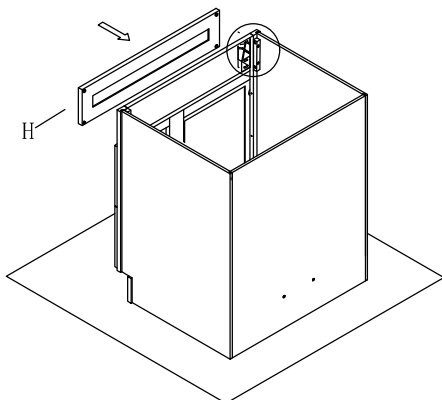

Step 16 : Finish installation of the cabinet.

